

COMAIR 20T

Commercial Whole-Building Indoor Air Treatment System

The Pentair® ComAir 20T is a powerful, commercial-grade HVAC sterilization system designed to reduce indoor airborne contaminants and unwanted odors, leaving behind fresh, cleaner air. Installed in the centralized HVAC system of your commercial space, the ComAir 20T provides "double-layered" protection with two specially-designed ultraviolet (UV) lamps.



HVAC45

Applications

- ◆ Restaurants
- ◆ Food processors
- ◆ Schools
- ◆ Hospitality
- ◆ Office buildings

Features • Benefits

- ◆ Adjustable output
- ◆ In-duct installation and operation
- ◆ Ozone and germicidal UV lamps
- ◆ Stainless steel construction
- ◆ Covers up to 6k square feet
- ◆ Quiet and energy efficient
- ◆ Microprocessor controlled
- ◆ Boost function for extreme odor control
- ◆ Universal power outlet

Installation Tips

- ◆ Installation only requires drilling four (4) holes.
 - The unit may be installed either in the return or the supply duct, locate it as far away from the heating source as practical while remaining in the main air stream.
- ◆ The unit can be installed with either lamp facing up, but should always be right side up.
- ◆ The unit automatically turns on and off with the airflow. It is not necessary to connect into switched power.

Includes

- ◆ ComAir 20T unit
- ◆ One (1) ozone lamp
- ◆ One (1) germicidal lamp
- ◆ One (1) lamp shield
- ◆ One (1) airflow PCB
- ◆ Four (4) self-tapping screws
- ◆ Installation and operation manual

Pentair ComAir 20T

Example Installation

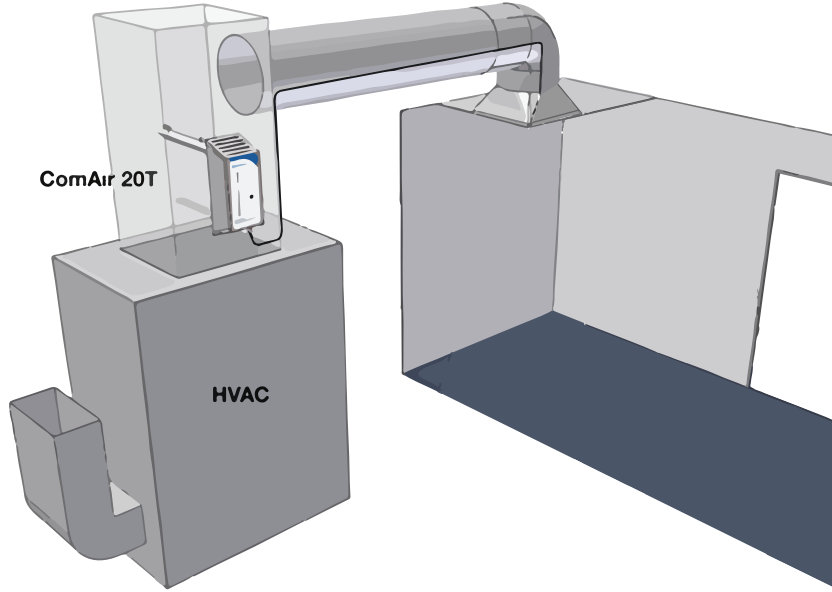

Specifications

- ◆ System (Model/Part No.)
HVAC45 unit
- ◆ Ozone Output
0.08 ppm; max @ 3500 CFM; depends on load in the air
- ◆ Power
90 - 265VAC, 50/60Hz
1.2 - 0.6A, 180W
- ◆ Minimum Duct Size
18" (45.72 cm)
- ◆ Dimensions
15.5" H x 5.5" W x 20" D
(39.4 cm x 14 cm x 50.8 cm)
- ◆ Exposed Size (outside of duct)
15.5" H x 5.5" W x 3.5" D
(39.4 cm x 14 cm x 8.9 cm)
- ◆ Weight
5 lbs (2.26 kgs)

OZONE LAMP	GERMICIDAL LAMP
Maximum service capacity: 20T, 8,000 CFM, or 6,000 sq. ft. per unit	Maximum service capacity: 20T, 8,000 CFM, or 6,000 sq. ft. per unit
AC unit size, maximum: 20 tons	AC unit size, maximum: 20 tons
25W, hot filament, instant-start, hard quartz, glass construction, unaffected by number of starts	17W, hot filament, instant-start, hard quartz, glass construction, unaffected by number of starts
185 nm wavelength output	90% of output at 254 nm wavelength
Rated Life: 20,000 hours (2-3 years continuous use)	Rated life: 20,000 hours (2-3 years of continuous use)
Maintenance: annual cleaning	Maintenance: annual cleaning
Ozone output settings are adjustable based on need (low, medium, high & boost)	Output (measurements taken at 70°F or 21°C) - 300 micro watts per sq. cm. at 39.37" (1m) - 2,400 micro watts per sq. cm at 12.00" - 7,450 micro watts per sq. cm at 6.00"



Pentair Offices in South East Asia

Singapore

390 Havelock Road
#04-01 King's Centre
Singapore 169662
Tel: +6567685900

Thailand

16th Floor, The Ninth Towers
Grand RAMA 9, Tower B
33/4 Rama 9 Road, Huaykwang
Bangkok 10310, Thailand
Tel: +6621681092

Philippines

5th Floor MAIA Suites
1747 Nicanor Garcia Street corner
D.Oliman Street Makati City, Philippines
Tel: +632824 3825